

10

9

8

7

6

5

4

3

NOTES:

ZONE	REV	DESCRIPTION	DATE	APPROVED

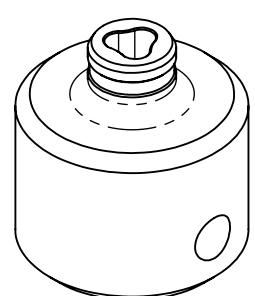
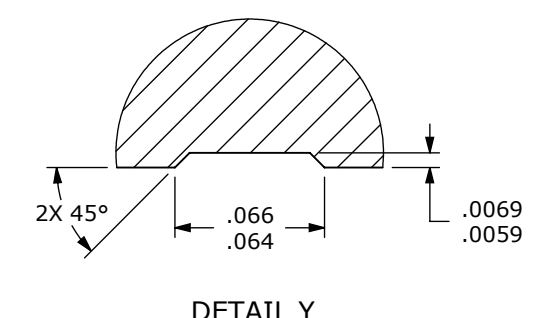
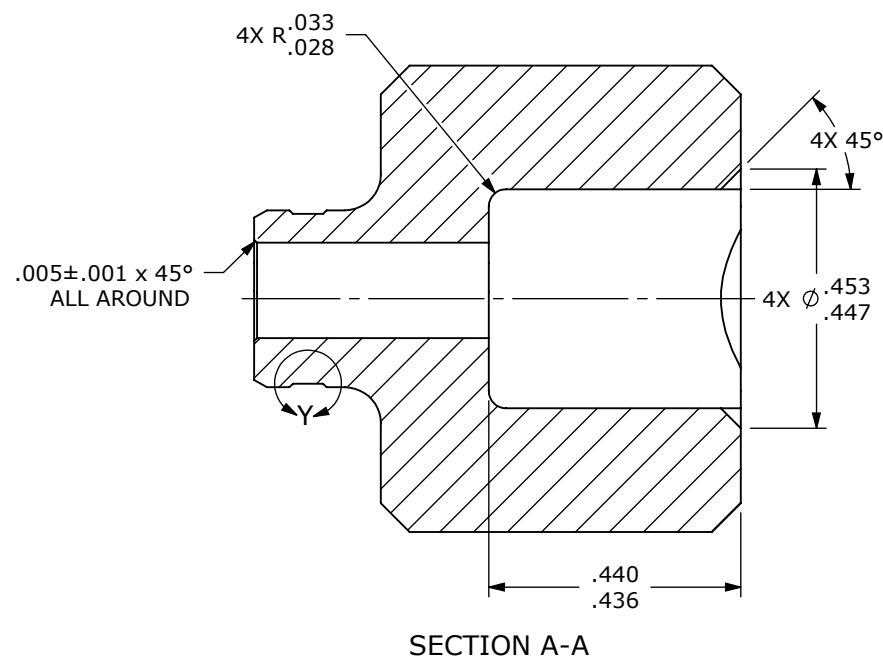
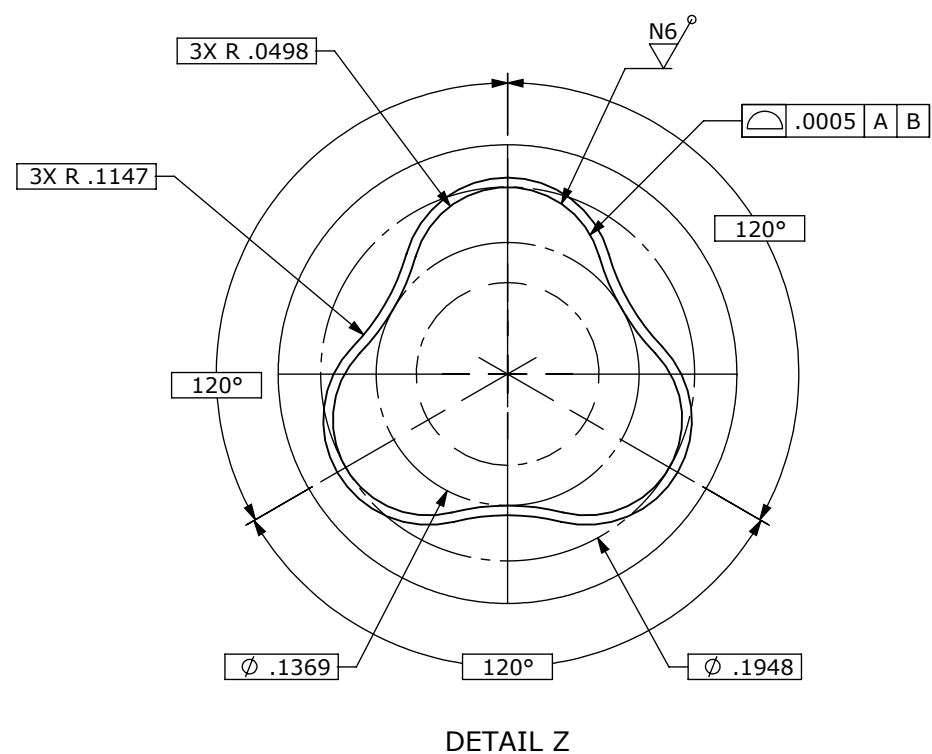
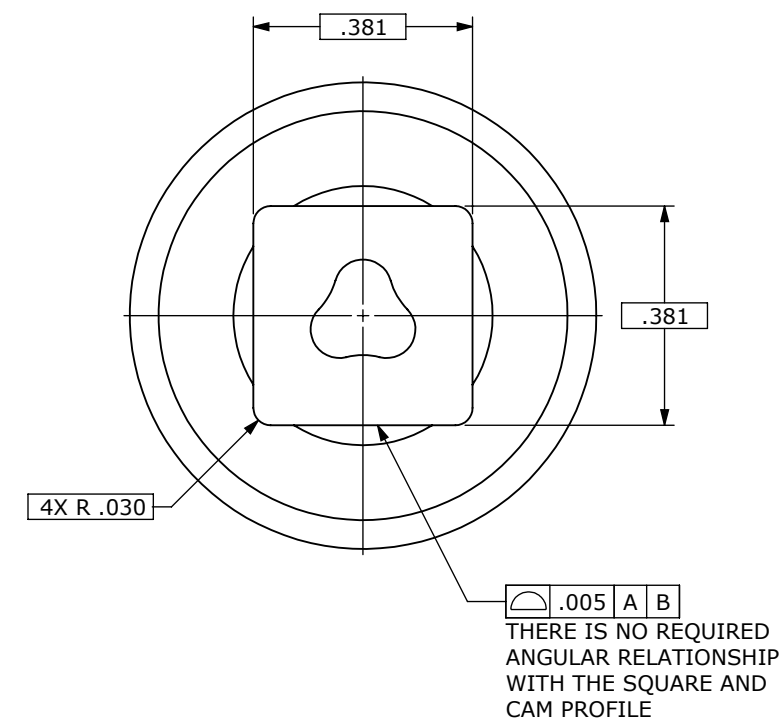
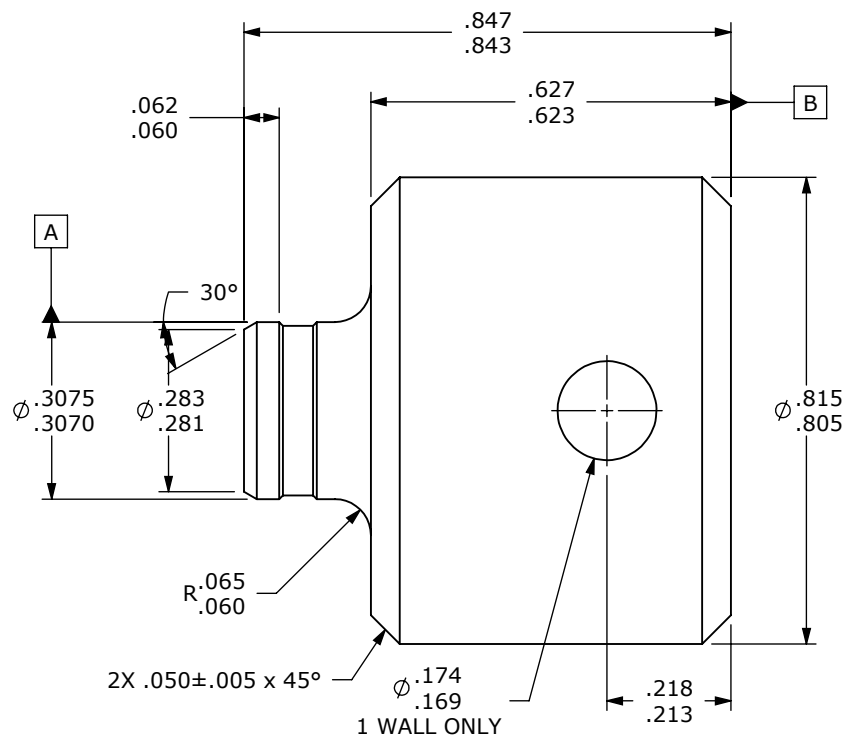
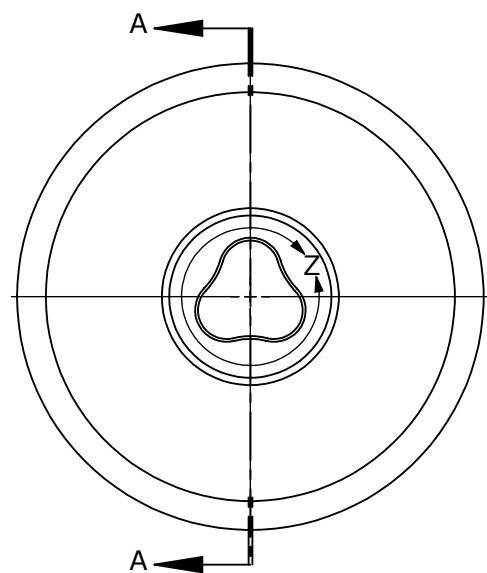

MATERIAL S7 TOOL STEEL	UNLESS OTHERWISE SPECIFIED DIMENSIONS ARE IN INCHES PER RC 54-57, THRU TOL. ON ANGLE ± 0.5 DEG REMOVE BURRS AND SHARP CORNERS MACH SURFACES 3.2 MAX	PROPRIETARY AND CONFIDENTIAL THE INFORMATION CONTAINED IN THIS DRAWING IS THE SOLE PROPERTY OF LUCAS TECHNICAL SERVICES. ANY REPRODUCTION IN PART OR AS A WHOLE WITHOUT THE WRITTEN PERMISSION OF LUCAS TECHNICAL SERVICES IS PROHIBITED.	40 CLARENDON DR. EASTON, PA 18040 www.LucasTechnical.com info@LucasTechnical.com 484-553-5965
HEAT TREAT N/A	DWN BY CKD BY	CLIENT -CLIENT NAME- -CLIENT ADDRESS-	DRAWING TITLE TOOL BODY
	LTAYLOR N/A	1/3/2011 N/A	PART NO. DFH1M6-0601
			REV A
			SHEET 1 of 1

10

9

8

7

6

5

4

3

2

1